

---

# Case Trim & Prep Center

---

## Care & Usage Instructions

SPECS: 120v~60Hz. 1.3A



# IMPORTANT SAFETY INSTRUCTIONS

## SAVE THESE INSTRUCTIONS

# STOP!

If you have a problem with this product, **DON'T RETURN IT TO THE STORE WHERE YOU PURCHASED IT.** Contact customer service at...

**Battenfeld**<sup>™</sup>  
Technologies, Inc.

5885 West Van Horn Tavern Road / Columbia, MO 65203  
573-445-9200 / Email: [sales@battenfeldtechnologies.com](mailto:sales@battenfeldtechnologies.com)  
Or visit our website @ [www.battenfeldtechnologies.com](http://www.battenfeldtechnologies.com)

## NOT WARRANTED AGAINST MISUSE, ABUSE, OR COMMERCIAL USE.

### Limited Warranty

Every Frankford product is warranted to be free of defects in materials and workmanship for a period of one (1) year from the date of original purchase. Frankford will, at its option, repair or replace without charge, except for transportation costs, parts that fail under normal use and service when operated and maintained in accordance with our Instructions. This warranty does not apply to normal wear or to items whose life is dependent upon their use and care. This warranty is in lieu of all other warranties, expressed or implied and releases Frankford, its affiliates, and its vendors from all other obligations and liabilities.

**WHEN USING THIS ELECTRICAL APPLIANCE BASIC PRECAUTIONS SHOULD ALWAYS BE FOLLOWED INCLUDING THE FOLLOWING:**



## WARNING:

**KEEP HANDS, HAIR, AND LOOSE CLOTHING AWAY FROM THE CUTTERS WHILE THE TRIM & PREP CENTER IS RUNNING.**

**NEVER TOUCH OR GRAB ANY CUTTERS OR TOOLS WHILE THE TRIM & PREP CENTER IS RUNNING.**

**NEVER ATTEMPT TO TIGHTEN, INSTALL, OR REMOVE ANY CUTTERS OR TOOLS WHILE THE TRIM & PREP CENTER IS RUNNING .**

**NOTE: NEVER RUN THE TRIM & PREP CENTER WITHOUT THE CASE HOLDER IN PLACE**

**IF THE TRIM & PREP CENTER BECOMES HOT TO THE TOUCH, DISCONTINUE USE IMMEDIATELY AND ALLOW IT TO COOL.**

# IMPORTANT SAFETY INSTRUCTIONS

## SAVE THESE INSTRUCTIONS

1. Read all instructions before using this appliance.
2. To reduce the risk of injury, close supervision is necessary when this appliance is used near children.
3. Do not contact moving parts.
4. Always wear safety glasses when using this appliance.
5. Do not use outdoors.
6. To disconnect, turn all controls to the OFF position, then remove the plug.
7. Do not unplug by pulling on the cord. To unplug, grasp the plug, not the cord.
8. Do not operate this appliance with a damaged cord or plug, or if the unit malfunctions or is dropped or damaged in any manner.  
Return the unit for examination, repair, or electrical or mechanical adjustment.
9. To reduce the risk of electrical shock, do not put this appliance in water or other liquid.
10. Do not place or store this appliance where it can fall or be pulled into a tub or sink.
11. Remove plug from wall outlet when this appliance is not in use.
12. Never operate this appliance unattended.
13. Operate this appliance on a non-combustible surface away from all combustible materials including curtains, draperies, or walls.

### For grounded appliance

Connect to a properly grounded outlet only.  
See Grounding Instructions.

This appliance must be grounded. In the event of malfunction or breakdown, grounding provides a path of least resistance for electric current to reduce the risk of electric shock. This appliance is equipped with a cord having an equipment-grounding conductor and a grounding plug. The plug must be plugged into an appropriate outlet that is properly installed and grounded in accordance with all local codes and ordinances.

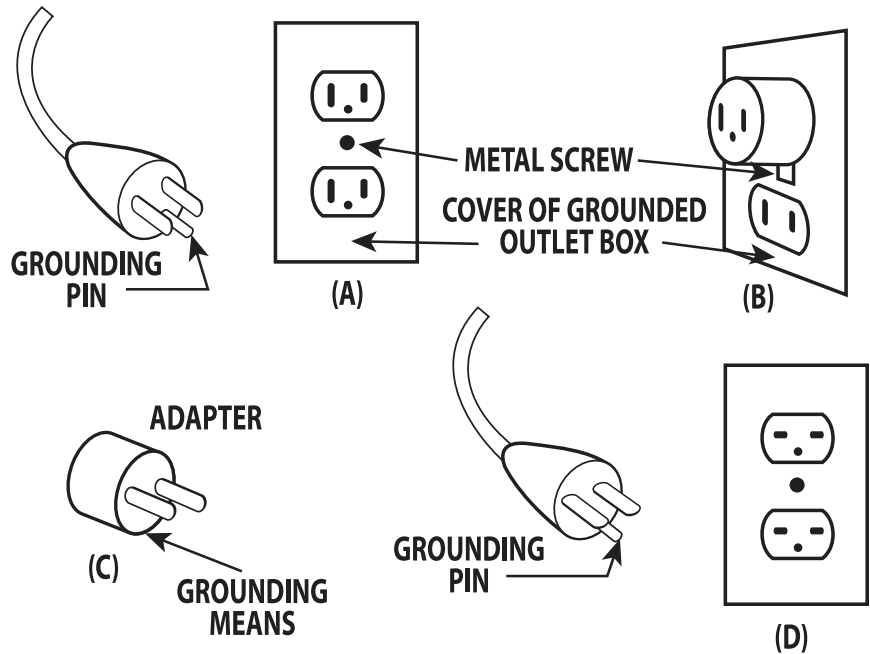

### DANGER:

Improper connection of the equipment-grounding conductor can result in a risk of electric shock. The conductor with insulation having an outer surface that is green with or without yellow stripes is the equipment-grounding conductor. If repair or replacement of the cord or plug is necessary, do not connect the equipment-grounding conductor to a live terminal. Check with a qualified electrician or serviceman if the grounding instructions are not completely understood, or if in doubt as to whether the appliance is properly grounded. Do not modify the plug provided with the appliance - if it will not fit the outlet, have a proper outlet installed by a qualified electrician.

This appliance is for use on a nominal 120 V circuit, and has a grounding plug that looks like the plug illustrated in sketch "A". A temporary adapter, which looks like the adapter in sketches "B" and "C", may be used to connect this plug to a 2-pole receptacle as shown in sketch "B" if a properly grounded outlet is not available. The temporary adapter should be used only until a properly grounded outlet can be installed by a qualified electrician. The green colored rigid ear, lug, and the like, extending from the Adapter must be connected to a permanent ground such as properly grounded outlet cover box. Whenever the adapter is used, it must be held in place by the metal screw.

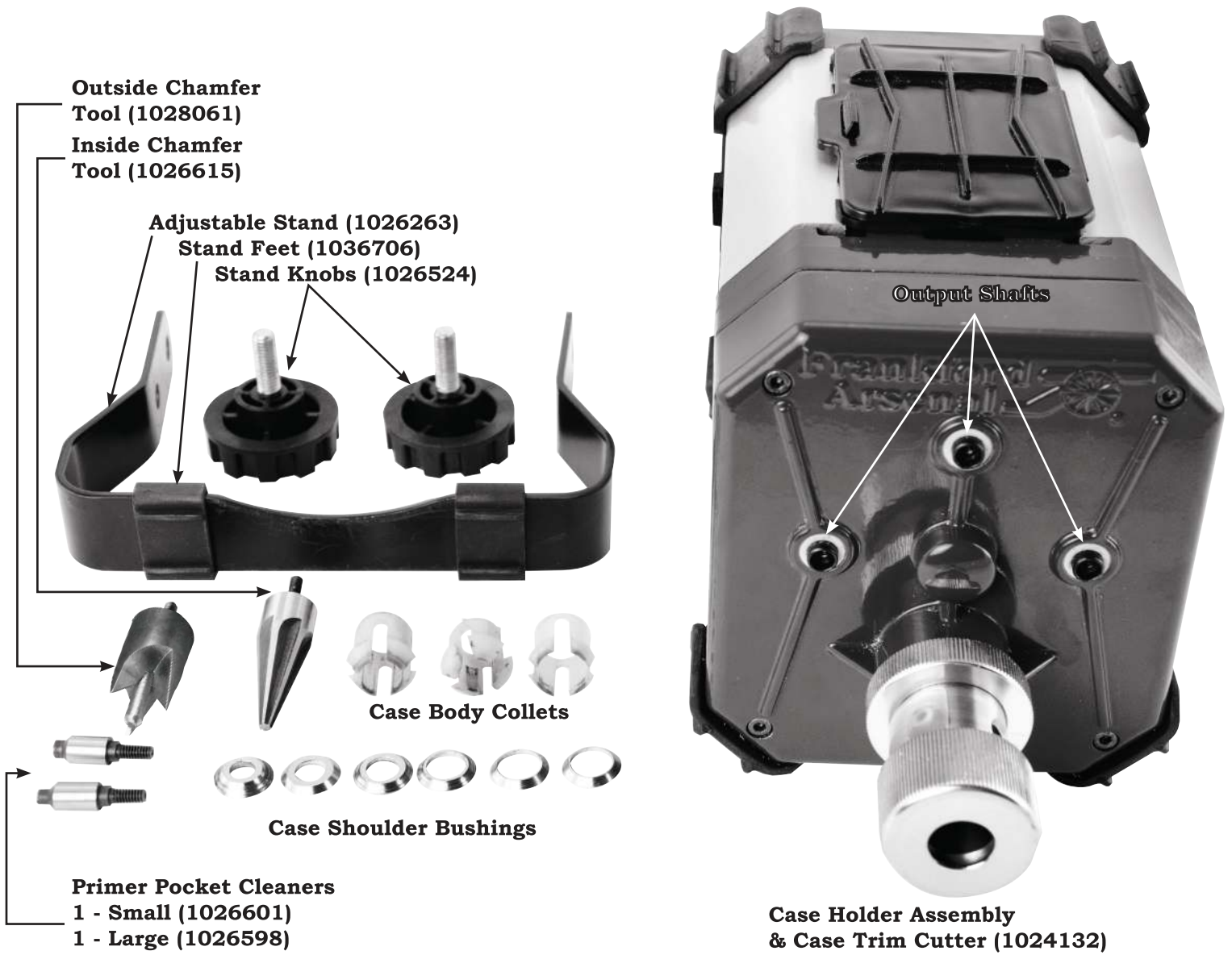

Please take a moment to locate all of the parts shown in this photo. Since we are always trying to improve our products, some components may vary slightly in appearance.

## Assembly Instructions

The Frankford Arsenal Case Trim & Prep Center only requires a few easy assembly steps before it is ready to use. Please follow these steps to assemble the device, using the Photograph on the following page as a reference if needed.

1. Slide the Adjustable Stand around the Trim & Prep Center so that one set of holes on the side align with the threaded holes on the sides of the device.

**NOTE:** There are two holes on the stand to provide different heights. Either set of holes may be used to achieve the desired height and angle, or the device can be set flat or upright without the stand. (See Page 10)

2. Insert the Stand Knobs through the holes in the Stand and tighten them securely into the sides of the Trim & Prep Center.
3. Remove the Chamfer Tools and the appropriate Primer Pocket Cleaner (See Above) from the Storage box on top of the device and thread them into any of the three output shafts indicated above. All three of these shafts rotate the same direction and speed.



# Case Trim & Prep Center Features

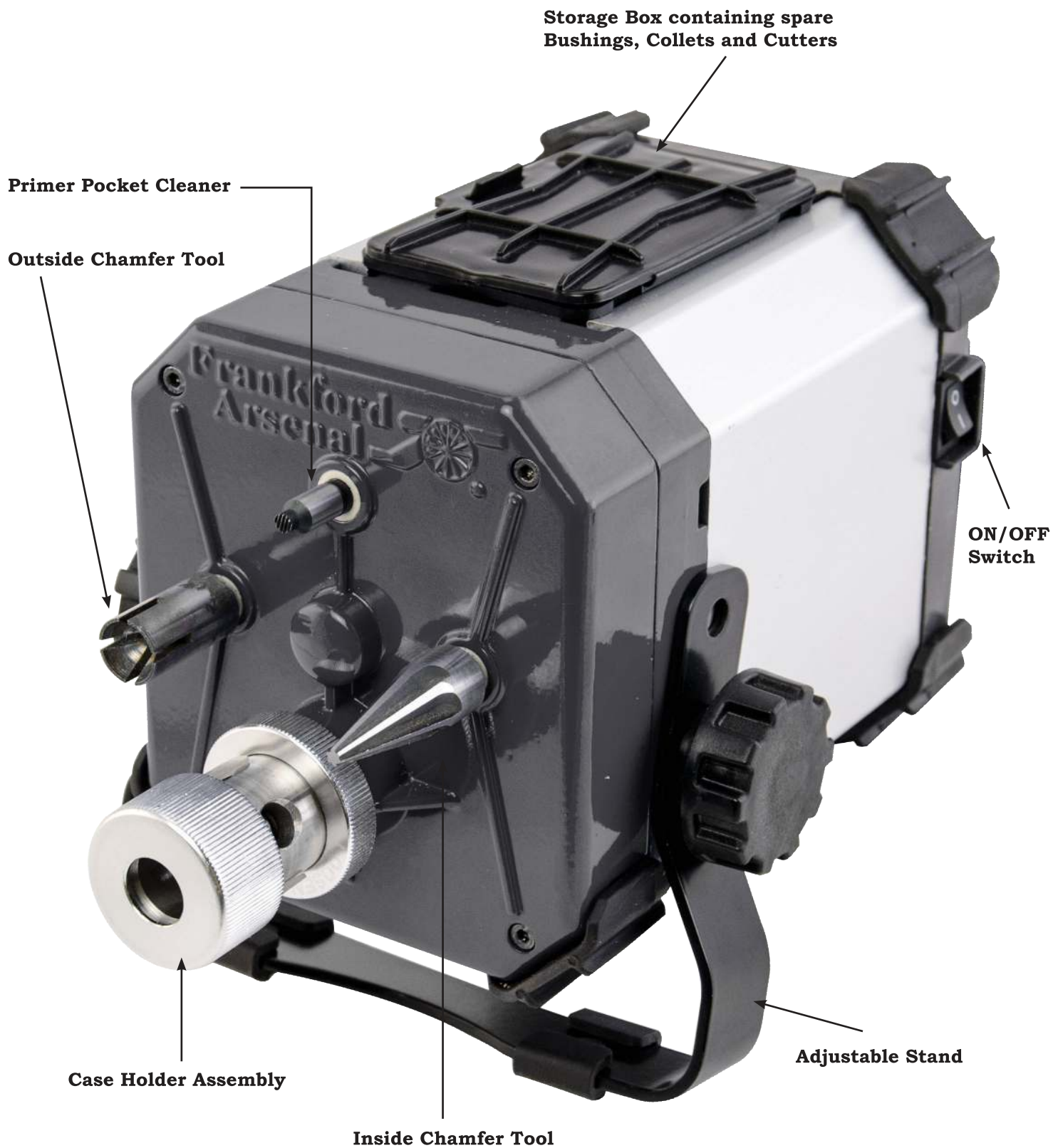

# Case Prep Overview

The Frankford Arsenal Case Trim & Prep Center is designed to quickly and easily trim and prepare nearly any caliber of rifle brass that has a shoulder. This device is able to trim brass to length, chamfer both the inside and outside of the case mouth, and clean the primer pocket. Below is a brief guideline to each of these functions. We strongly recommend you fully read and understand a comprehensive reloading manual before attempting to reload any ammunition.

## Case Trimming

When a rifle is fired, the chamber pressure created by the burning powder causes the brass cartridge case to swell. After the pressure is gone, this swelling leaves the case slightly larger than before. In order to reload the case, the size must be reduced by “resizing” the case. During this resizing operation, the brass “flows” forward and causes the length of the case to increase.

Every caliber has a specified maximum case length that is safe for firing. Cases longer than this must have the excess length removed in order to ensure maximum safety. The Frankford Arsenal Case Trim & Prep Center will quickly and easily cut away this excess length. Other benefits to trimming cases is that it will ensure that the case mouth is square which allows for better accuracy and may also be required for a firm crimp on the bullet.

The Case Trim & Prep Center uses an adjustable assembly called the Case Holder to align and position the cases for trimming. Using a series of Shoulder Bushings and Body Collets, we have eliminated the need for caliber-specific shell holders or plates by positioning the case using the shoulder, similar to how the rifle’s headspace is measured. By using the shoulder of the case, any variation in the case’s headspace won’t affect the trim length. However, when measuring overall case length some variation may still be seen due to variations in case headspace. The variation is normal and not an indication of inconsistent trimming. The following pages will provide more detail on how to trim cases using the Case Trim & Prep Center.

## Case Chamfering

After trimming to length, a sharp, square edge is left on the case mouth. Chamfering is the operation to cut away this sharp edge and leave a clean, tapered edge. Correct chamfering of the inside of the case allows for easy loading of bullets and improves accuracy by reducing “bullet shaving”. Lightly chamfering the outside edge will allow for smooth feeding of rounds into the rifle’s chamber.

The Case Trim & Prep Center includes separate cutters for chamfering both the inside and the outside of the case mouth. These cutters are universal and will work with any caliber case from .17-.45. To use these, you simply hold the case mouth against the end of the cutter using light pressure for a few moments. The intent of case chamfering is only to remove sharp edges, not to cut away significant amounts of material. A correctly chamfered case will have a small, shiny ring visible on the inside edge of the case mouth and have a smooth, clean outside edge. You do not want to chamfer the case so heavily that the case mouth becomes a sharp edge (See figure below).

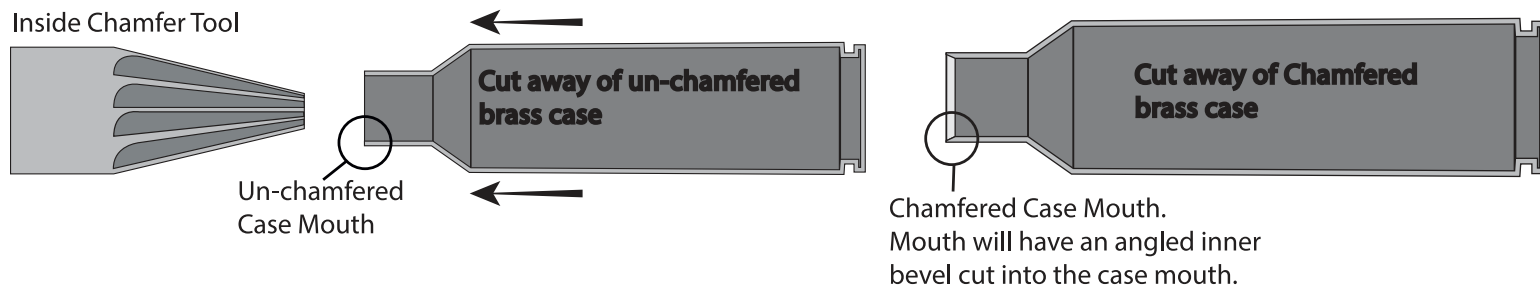

## Primer Pocket Cleaning

The Case Trim & Prep Center also includes two Primer Pocket Cleaning tools. These tools have a grooved face that will scrape away any residue from the primer pocket to ensure new primers are fully seated. They are not intended to cut away case material and should only be used with light pressure. Also, if the primer pockets are not flat, the center section may not be fully cleaned. There are two Primer Pocket Cleaners included, small and large. The Primer Pocket Cleaner must match the primer size on the brass being prepared.

# How the Case Holder Works

**NOTE:** Because the trim length is determined by the shoulder of the case, all cases should be cleaned and sized before trimming to provide the most accurate and repeatable result.

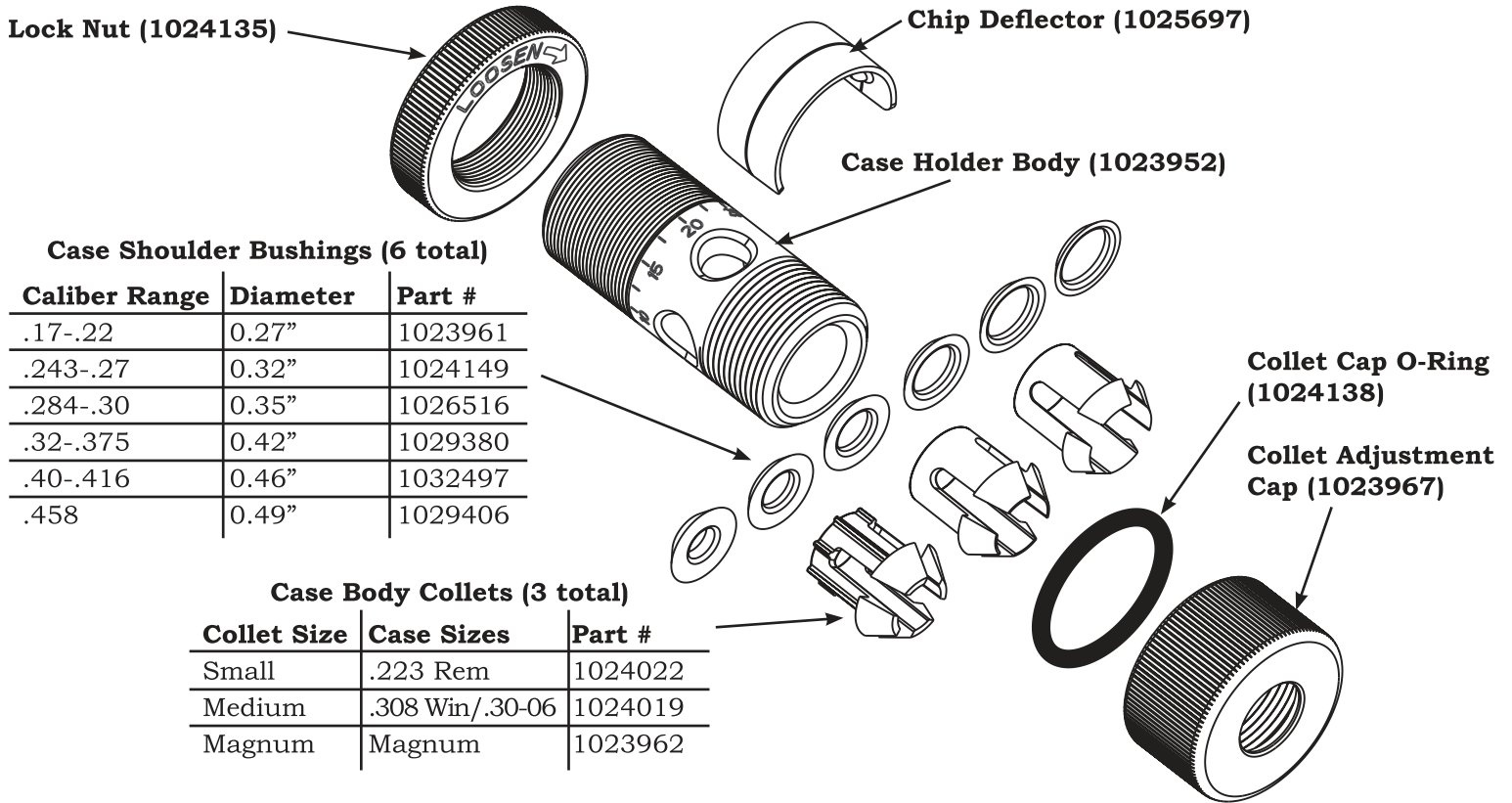

## How to determine which Case Shoulder Bushing is the best fit

1. Reference the Caliber Range in the table of Case Shoulder Bushings above
2. Slide the bushing over the neck of the case as shown
3. The back edge of the correct bushing will stop near the middle of the case shoulder (See Figure Below)

**NOTE:** More than one Bushing may be compatible with some cases

**IDEAL:**  
The Back edge of the bushing is centered on the case shoulder

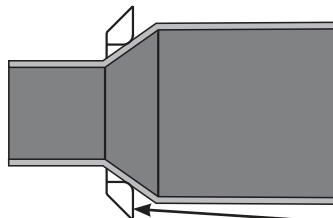

**NOT IDEAL:**  
The Back edge of the bushing is NOT centered on the shoulder

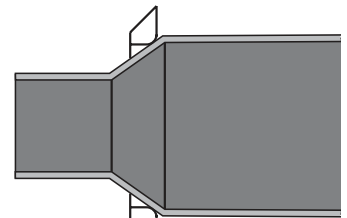

Case Shoulder Bushing

## How to determine which Case Body Collet is the best fit

1. Reference the Case Sizes for each collet in the table of Case Body Collets above
2. Choose the smallest collet that will still allow the case to slide freely through it (See Below)
3. During adjustment (See next page) the Collet Adjustment cap will compress the collet and eliminate any side-to-side play of the case while trimming

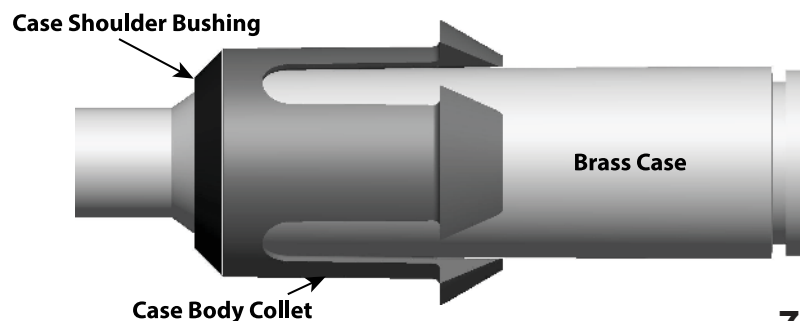

# Case Holder Assembly

1. Loosen the Lock Nut and remove the Case Holder Assembly from the Trim & Prep Center

**NOTE:** The Case Holder has Left-Hand threads so it must be turned **CLOCKWISE** to loosen

2. Unscrew the Collet Adjustment Cap to allow access inside the Case Holder (COUNTERCLOCKWISE)
3. Place the appropriate Shoulder Bushing onto an empty case with the tapered side forward as shown below
4. Insert the Case with the Bushing into the Case Holder
5. Slide the appropriate Collet over the case and into the Case Holder, with the tapered end out, as shown below
6. Replace the Collet Adjustment Cap, ensuring the O-ring is fully seated in the groove in the Cap

**NOTE:** To start the threads, place the O-ring into the Adjustment Cap and press the cap onto the Case Holder until you feel the O-ring “snap” over the threads. Then screw the Adjustment Cap clockwise. (See the Troubleshooting section on Page 10 for more details)

7. Tighten the Collet Adjustment Cap until the Case cannot move sideways but is still easy to insert and remove from the Case Holder.

**NOTE:** Never over-tighten or fully collapse the Case Body Collets as it may damage them

8. Remove the empty case and then screw the Case Holder assembly COUNTERCLOCKWISE back into the Trim & Prep Center until the cutter is just visible through the holes. The trim length adjustment method is described below.

## Adjusting the Trim Length

With the Motor OFF, Adjust the Trim Length of the Case Holder Assembly as described below.

1. If tight, loosen the Lock Nut by turning it clockwise
2. Insert an empty, sized case and rotate the entire Case Holder Assembly until the case mouth is just touching the cutter (See note below)

**NOTE:** The Case Holder has Left-Hand threads so it adjusts as follows:

**CLOCKWISE – MOVE CASE AWAY FROM CUTTER (INCREASE TRIMMED CASE LENGTH)**

**COUNTERCLOCKWISE – MOVE CASE TOWARD CUTTER (DECREASE TRIMMED CASE LENGTH)**

4. Remove the empty case, re-tighten the Lock Nut until it is hand-tight and turn the Motor ON.
5. Insert the empty, sized case, and with light pressure, advance it into the cutter until it stops. When the case shoulder stops against the Case Holder Assembly it is fully trimmed, and additional force or time will not cut it any further.
6. Remove the trimmed case and turn the Motor OFF
7. Measure the trimmed case and fine-tune the trim length by making small adjustments and re-trimming and measuring often.

**TIP:** The Case Holder has numbered reference marks corresponding to a 0.005” length adjustment. The minor reference marks (no numbers) correspond to 0.0025” adjustment in trim length each. For example moving case holder from 15 to 20 will decrease trimmed case length by approx. .005”

8. Once the Case Holder adjustment is correct, tighten the Lock Nut (counterclockwise) until it is hand-tight

**NOTE:** Never use wrenches or pliers to tighten as it may damage the machine

9. Remove and reposition the Chip Deflector so that it’s located on the top side of the Case Holder

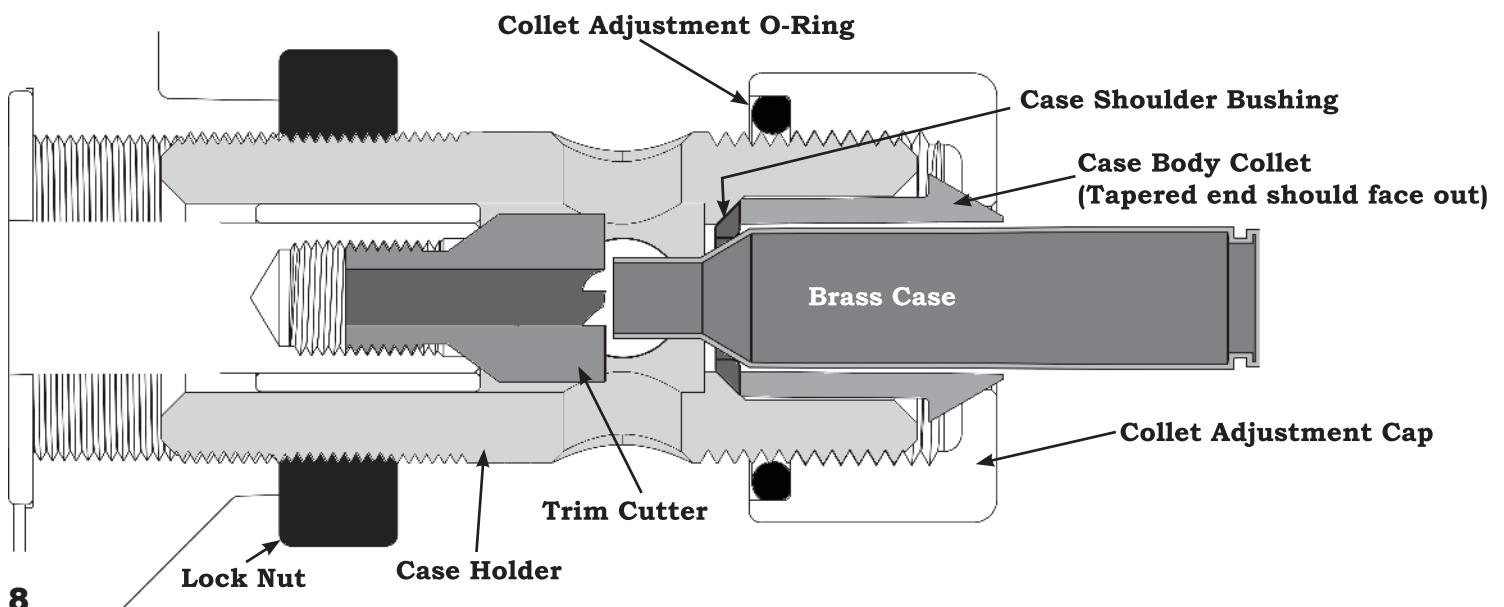



# Operating Instructions

---

**NOTE:** Use only Brass or Nickel-Plated Cases, use of steel or any other material may damage the cutter or machine

1. Adjust the Stand to the desired angle, ensuring the knobs are tightened securely.

**TIP:** The Case Trim & Prep Center can also be used without the stand or it can be used standing up vertically on the base.

**IMPORTANT: The motor of the Trim & Prep Center requires airflow for ventilation while in use. Never place the Machine so that the vents on the Base or around the sides are blocked.**

2. Adjust the Case Holder for the correct trim length as described in the Adjustment section.  
Ensure that the Lock Nut is securely tightened.

3. Ensure that the Chamfer Tools and Primer Pocket Cleaner are installed and securely tightened  
Always verify that the Case Holder is in place and the Lock Nut is tightened before turning the Motor ON.

4. Insert an empty, sized case into the Case Holder. Using light pressure, advance the case into the cutter.

**TIP:** Allow the cutter to do the work and use light pressure against the case. "Jamming" cases into the cutter will create rough and inaccurate cuts and could damage the cutter or the case

5. The case is fully trimmed when the shoulder stops against the Bushing. At this point, maintain pressure on the case and rotate it CLOCKWISE one-half turn. This will help to ensure that the case mouth is cut squarely.

6. After trimming, remove the case and lightly press the case mouth against the Inside and Outside Chamfer Tools.  
Only a few seconds on each cutter is required to debur and chamfer the case.

**TIP:** See Case Chamfering Section of Page 6 for more detail

7. If desired, the Primer Pocket can also be cleaned by placing the case onto the Primer Pocket  
Cleaning Tool and applying light pressure for a few seconds.

**TIP:** See Primer Pocket Cleaning Section of Page 6 for more detail

## Maintenance & Care

---

**NOTE:** The gears and bearings inside the Trim & Prep Center are lubricated and sealed at the factory. Never open the gear box. If you are experiencing problems, please reference the Maintenance and Troubleshooting sections below. If the problem persists, call Battenfeld Technologies, Inc. Customer Service.

1. Keep all threads clean and free from brass shavings. If threads are difficult to turn, remove the parts and clean the threads to avoid damage.

2. Periodically remove the Case Holder Assembly and remove any brass shavings that may accumulate inside of it.



3. Keep the Case Holder and Output Shafts clean. If stored in a humid environment, lightly oiling these parts will help prevent corrosion.

4. Replacing Cutters: If the cutter becomes damaged or dull from use; it may be replaced by removing the Case Holder Assembly and unscrewing the Cutter from the shaft. The Cutter uses a common 3/8"-24 UNF thread size and is compatible with many after-market cutters.

**NOTE:** To remove a stuck cutter, the cutter shaft may be held firmly with a pair of padded pliers. Never grip the shaft directly with pliers or wrenches as they can damage the Shaft.

# Troubleshooting

If you are experiencing problems with the Case Trim & Prep Center, please see the table below for common remedies before calling Battenfeld Technologies, Inc. Customer Service.

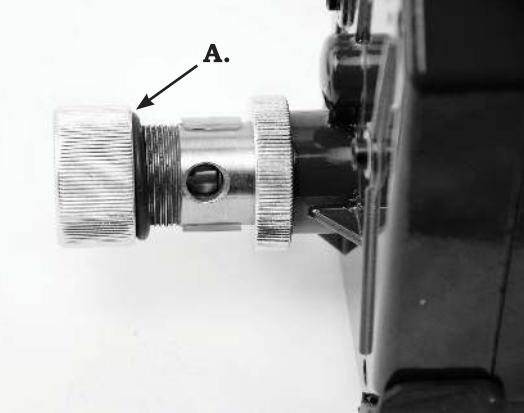
<b>Problem</b>	<b>Remedy</b>
Cut quality is not good	<ol style="list-style-type: none"> <li>1. Use less force on Case when trimming. Aggressive cuts can cause the cutter to dig into and gouge the case mouth.</li> <li>2. Use more force on Case when trimming. Too light of force on the case may allow the case to “chatter” on the cutter.</li> <li>3. Replace Cutter as described on Page 9.</li> </ol>
Trim length varies more than desired	<ol style="list-style-type: none"> <li>1. Ensure all cases are properly cleaned and sized</li> <li>2. Always chamfer and deburr cases before measuring. Burrs from cut can cause inaccurate measurements</li> <li>3. Check that proper Bushing and Collet are being used</li> <li>4. Ensure that cases are stopping fully against bushing during trimming</li> <li>5. Rotate case ½-turn clockwise while trimming. This helps ensure a square cut on the case mouth</li> </ol>
Device slides when case is trimmed	<ol style="list-style-type: none"> <li>1. Use hands to brace device while feeding cases into cutters</li> <li>2. Place device on non-skid mat such as Tipton® Maintenance Mat</li> <li>3. Change orientation of device with adjustable stand as shown below.</li> </ol> 
Collet Adjustment Cap is difficult to install or O-ring is difficult to keep in place	<ol style="list-style-type: none"> <li>1. Place the O-ring into groove in adjustment cap as shown below. With the O-ring in the cap, align the Cap with the Case Holder and press firmly until you feel the O-ring “snap” over the threads. Once the O-ring is over the threads, rotate the Adjustment Cap clockwise to adjust the Collet.</li> <li>2. If the O-ring comes out of the groove while adjusting the Cap <b>(A.)</b> it can be forced back in place by your fingertips or a blunt tool such as a screwdriver.</li> </ol>
 <p>1.</p>	 <p>2. Press Firmly onto threads</p>  <p>A.</p>
Cutters do not rotate when device is turned on or stop during use	<p><b>NOTE: Turn OFF and Unplug device before troubleshooting</b></p> <ol style="list-style-type: none"> <li>1. Check Power Cord for damage</li> <li>2. Remove Case Holder Assemble and clean any brass shavings from inside Case Holder and around the Cutter and shaft</li> </ol> <p><b>NOTE: Replace Case Holder before turning device ON</b></p>

---

# Case Trim & Prep Center

---





5885 West Van Horn Tavern Road / Columbia, MO 65203  
573-445-9200 / Email: [sales@battenfeldtechnologies.com](mailto:sales@battenfeldtechnologies.com)